

SL30P

250

stroke / carrera

	row pads / patines
S	ball row pads patines a bolas
R	roller pads patines a rodillos

	cylinder / cilindro
08	ø 80
10	ø 100

	limit switches position / posición final de carrera
MR	magnetic sensor on cylinder, hydrocheck on right side. sensor magnético en cilindro, regulador en el lado derecho.
ML	magnetic sensor on cylinder, hydrocheck on left side. sensor magnético en cilindro, regulador en el lado izquierdo.
R	cam+switches on right side, hydrocheck on left side. final de carrera lado derecho, regulador en el lado izquierdo.
L	cam+switches on left side, hydrocheck on right side. final de carrera lado izquierdo, regulador en el lado derecho.

	front safety guard / protección anterior
0	without safety guard sin protección

	rear safety guard / protección posterior
0	without safety guard sin protección

	hydrocheck / regulador
100H	standard

STANDARD COLOR

 RAL 1001

OPTIONAL COLORS

 RAL 1013

 RAL 1023

 RAL 2003

 RAL 3028

 RAL 5015

 RAL 6018

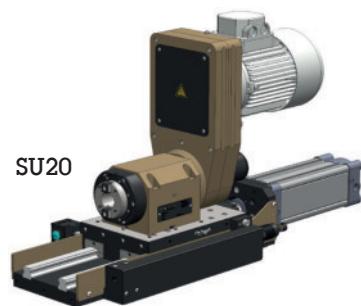

SU20

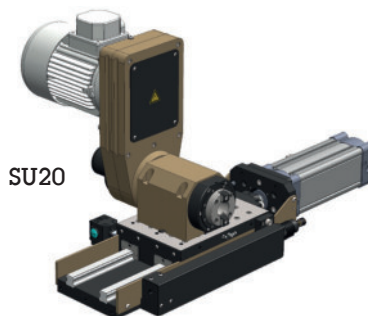

SU20

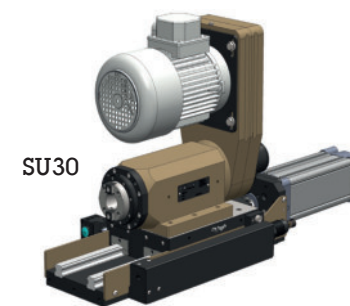

SU30

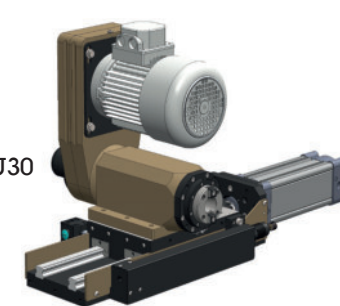

SU30